

Performance Evaluation on Mass Recovery Three-Bed Adsorption Chiller

Gulshan Khatun¹✉, Zafar Iqbal Khan²

¹Department of Computer Science and Engineering, Eastern University, Dhaka, Bangladesh

²Department of Mathematics, Bangladesh University of Engineering & Technology, Dhaka, Bangladesh

Abstract: In this paper, the performance of a three-bed (equal bed) adsorption chiller with mass recovery has been numerically studied. The mass recovery scheme is used to improve the cooling effect and a CFC-free-based sorption chiller driven by the low-grade waste heat or any renewable energy source can be developed for the next generation of refrigeration. Silica gel/water is taken as adsorbent/adsorbate pair for the present chiller. The three-bed adsorption chiller comprises with three adsorber/desorber heat exchanger, one evaporator and one condenser. In the present numerical solution, the heat source temperature variation is taken from 50^oC to 65^oC along with coolant inlet temperature at 30^oC and the chilled water inlet temperature at 14^oC. In the new strategy, mass recovery process occurs in all beds. The configuration of beds in the three bed chiller with mass recovery were taken as uniform in size. The cycle simulation calculation indicates that the COP value of the three-bed adsorption chiller with mass recovery is 0.6214 with a driven heat source temperature at 65^oC in combination with coolant inlet and chilled water inlet temperatures at 30^oC and 14^oC, respectively.

Keywords: Renewable Energy Sources, Silica Gel-Water, Mass Recovery, Adsorption Chiller, Cooling Capacity and Coefficient of Performance

Introduction

Most of the advanced cycles in adsorption refrigeration/heat pump are proposed to achieve high Coefficient of Performance (COP) and/or Cooling Capacity (CC) values. Few cycles, however, are proposed to utilize relatively low temperature heat source. Saha et al. [1] proposed two-stage chiller where the driving heat source temperature was validated experimentally. A two-stage silica gel-water adsorption refrigeration cycle can exploit the heat source of temperature around 60^oC with the cooling source at 30^oC. Khan et al. [2] studied the performance investigation on mass recovery three-bed adsorption cycle. Later, Khan et al. [3] proposed and investigated numerically the advanced three-bed adsorption chiller employing mass recovery scheme. Saha et al. [4] studied waste heat driven dual-mode, multi-stage, multi-bed regenerative adsorption system. A novel adsorption chiller, namely, “Three - bed adsorption chiller” is also investigated by Saha et al. [5] and shown that waste heat recovery efficiency of the three-bed system is about 35% higher than that of the two-bed system.

To improve the coefficient of performance, Shelton et al. [6] proposed a thermal wave regenerative adsorption heat pump system. Wang [7] showed that mass recovery process is very effective for the high evaporating pressure lift as well as for the low regenerating temperature. Alam et al. [8] analyzed four-bed mass recovery cycle with silica gel/water

pair employing a new strategy to improve the cooling effect. Recently, Saha et al.[9] analyzed a dual-mode, multi-bed adsorption chiller to improve the heat recovery efficiency.

The performance of the adsorption refrigeration cycle can be enhanced by applying a mass recovery cycle into the adsorption cycle. The advanced mass recovery cycle was also applied to a three-bed cycle. Recently, Khan et al. [10] studied experimentally on a three-bed adsorption chiller and reported that it provided better COP values for 65-75^oC heat source temperature.

The Primary objective of the study is to determine the numerical result of a three-bed (equal-bed) adsorption chiller with mass recovery. A cycle simulation computer program is constructed to analyze the influence of operating conditions (hot and cooling water temperature) on COP (Coefficient of Performance) and CC (Cooling Capacity).The effect of cycle time on CC and COP are also discussed in the present study.

Working Principal of the Mass Recovery Chiller

The schematic diagram and time allocation of the proposed three-bed mass recovery chiller are shown in Figure 1 and Table 1, respectively. The three-bed mass recovery chiller comprises with three sorption elements (adsorber/desorber heat exchangers), a condenser, an evaporator, and metallic tubes for hot,

This article is published under the terms of the Creative Commons Attribution License 4.0

Author(s) retain the copyright of this article. Publication rights with Alkhaer Publications.

Published at: <http://www.ijsciences.com/pub/issue/2019-12/>

DOI: 10.18483/ijSci.2224; Online ISSN: 2305-3925; Print ISSN: 2410-4477



Gulshan Khatun (Correspondence)

+

cooling and chilled water flows as shown in Figure 1.

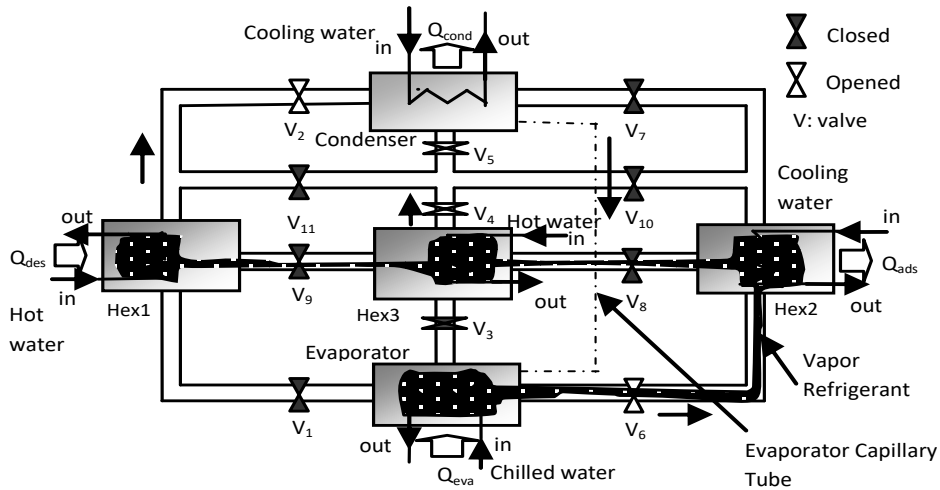
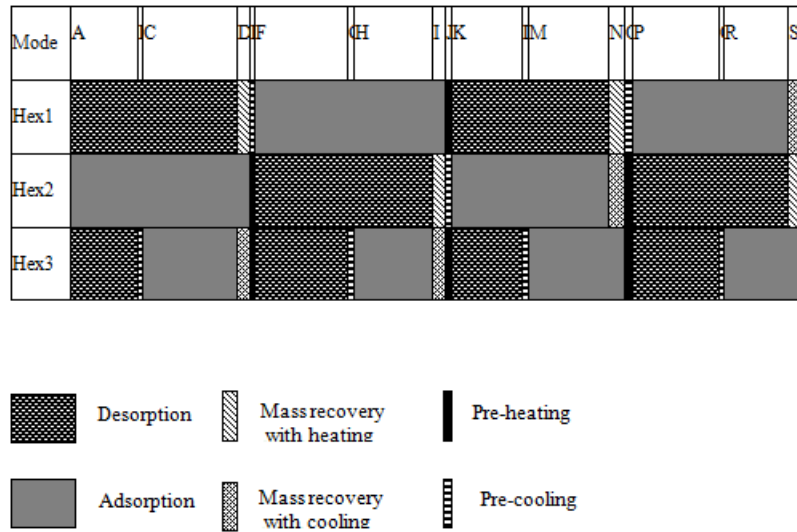

Figure 1. Schematic of three bed chiller with mass recovery

Operational strategy of the proposed chiller is shown in Table 1. In proposed design, mass recovery process occurs in all bed. To complete a full cycle for

the proposed system, the chiller needs 20 modes, namely A, B, C, D, E, F, G, H, I, J, K, L, M, N, O, P, Q, R, S and T as can be seen from Table 1.

Table 1. Operational Strategy of Three Bed Chiller with Mass Recovery



In mode A, Hex1 and Hex3 work as desorber. The desorption-condensation process takes place at condenser pressure (P_{cond}). The desorber (Hex1, Hex3) is heated up to temperature (T_{des}) by heat input Q_{des} , provided by the driving heat sources. The resulting refrigerant is cooled down by temperature (T_{cond}) in the condenser by the cooling water, which removes condensation heat, Q_{cond} . Hex2 works as adsorber in mode A. In the adsorption-evaporation process, refrigerant (water) in evaporator is evaporated at evaporation temperature, T_{eva} , and seized heat, Q_{eva} from chilled water. The evaporated

vapor is adsorbed by adsorbent (silica gel), at which cooling water removes the adsorption heat, Q_{ads} . Mode B is the pre-cooling process for Hex3. In pre-cooling process, Hex3 is isolated from evaporator, condensed or any other beds. Cooling water is supplied to the bed for short time (30s) in this period. Hex1 works as desorber and Hex2 works as adsorber in mode B also. Mode C is the adsorption process for Hex3, Hex2 and desorption process for Hex1. In mode D, Hex3 (at the end position of adsorption-evaporation process) and Hex1 (at the end position of desorption-condensation process) are connected with

each other continuing cooling water and hot water, respectively that can be classified as two-bed mass recovery process. This time Hex3 is isolated from evaporated and Hex1 is isolated from condensed. Here mass recovery occurs only bed to bed. In this mode Hex2 works as adsorber. When the concentration levels of both beds Hex1 and Hex3 reach in nearly equilibrium levels, then warm up process will start, called mode E (pre-heating or pre-cooling).

In mode E, Hex2 and Hex3 are heated up by hot water, and Hex1 is cooled down by cooling water. When the pressure of Hex2 and Hex3 are nearly equal to the pressure of condenser then Hex2 and Hex3 are connected to condenser. When the pressure of Hex1 is nearly equal to the pressure of evaporator then Hex1 is connected to evaporator. In mode F, Hex2 and Hex3 work as desorber and Hex1 works as adsorber. Mode G is the pre-cooling process for Hex3. In this mode, Hex2 works as desorber and Hex1 works as adsorber. Mode H is the adsorption-evaporation process for Hex1 and Hex3. Hex2 works as desorber in this mode. In mode I, Hex3 (at the end position of adsorption-evaporation process) and Hex2 (at the end position of desorption-condensation process) are connected with each other continuing cooling water and hot water, respectively that can be classified as two-bed mass recovery process. When the concentration levels of both beds Hex3 and Hex2 reach in nearly equilibrium levels, then warm up process will start, called mode J (pre-heating or pre-cooling). Hex1 works as adsorber in this mode. Mode J is the pre-heating/pre-cooling process for all bed. In this period, Hex1 and Hex3 are heated up by hot water; Hex2 is cooled down by cooling water. Modes K, L and M are same as modes A, B and C

respectively. In mode K, L and M Hex1 and Hex3 work as desorber and Hex2 works as adsorber. The mode N is same as mode D. In these modes, Hex2 (at the end position of adsorption-evaporation process) and Hex1 (at the end position of desorption-condensation process) are connected with each other continuing cooling water and hot water respectively. In this mode Hex3 works as adsorber. When the concentration levels of both beds Hex1 and Hex2 reach in nearly equilibrium levels, then warm up process will start, called mode O (pre-heating or pre-cooling). The mode O is same as mode E. Modes P, Q and R are same as modes F, G and H respectively. In mode P, Q and R, Hex2 and Hex3 work as desorber and Hex1 works as adsorber. The mode S is same as mode I. In mode S, Hex1 (at the end position of adsorption-evaporation process) and Hex2 (at the end position of desorption-condensation process) are connected with each other continuing cooling water and hot water, respectively that can be classified as two-bed mass recovery process. When the concentration levels of both beds Hex1 and Hex2 reach in nearly equilibrium levels, then warm up process will start, called mode T (pre-heating or pre-cooling). Hex3 works as adsorber in this mode. Mode T is the pre-heating/pre-cooling process for all bed. In this period, Hex1 and Hex3 are heated up by hot water; Hex2 is cooled down by cooling water. Mode T is the last process for all beds, after this mode, all beds will return to its initial position (Mode A). That's why to complete one cycle, it needs 20 modes.

Mathematical Formulation

The heat transfer and energy balance equations for the adsorbent bed can be described as follows:

$$T_{w, out} = T_{hex} + (T_{w, in} - T_{hex}) \exp\left(-\frac{U_{hex} A_{hex}}{\dot{m}_w C_{pw}}\right) \tag{1}$$

$$\frac{d}{dt} \{ (W_s (C_{ps} + C_{pw} q) + W_{khex} C_{pcu} + W_{fhex} C_{pAl}) T_{hex} \} = W_s Q_{st} \frac{dq}{dt} - \delta W_s C_{pw} \{ \gamma (T_{hex} - T_{eva}) + (1 - \gamma) (T_{hex} - T_{ww}) \} \frac{dq}{dt} + \dot{m}_w C_{pw} (T_{w, in} - T_{w, out}) \tag{2}$$

where, δ is either 0 or 1 depending whether the adsorbent bed is working as desorber or adsorber and γ is either 1 or 0 depending on whether the bed is connected with evaporator or another bed.

The heat transfer and energy balance equations for evaporator can be expressed as:

$$T_{chill, out} = T_{eva} + (T_{chill, in} - T_{eva}) \exp\left(-\frac{U_{eva} A_{eva}}{\dot{m}_{chill} C_{p, chill}}\right) \tag{3}$$

$$\frac{d}{dt} \{ (W_{eva, w} C_{pw} + W_{eva} C_{p, eva}) T_{eva} \} = -L W_s \frac{dq_{ads}}{dt} - W_s C_{pw} (T_{cond} - T_{eva}) \frac{dq_{des}}{dt} + \dot{m}_{chill} C_{p, chill} (T_{chill, in} - T_{chill, out}) \tag{4}$$

The heat transfer and energy balance equations for condenser can be written as:

$$T_{cond, out} = T_{cond} + (T_{cw, in} - T_{cond}) \exp\left(-\frac{U_{cond} A_{cond}}{\dot{m}_{cw} C_{pw}}\right) \quad (5)$$

$$\begin{aligned} \frac{d}{dt} \{ (W_{cw,w} C_{pw} + W_{cond,hex} C_{p,cond}) T_{cond} \} = \\ - L W_s \frac{dq_{des}}{dt} - W_s C_{p,w} (T_{des} - T_{cond}) \frac{dq_{des}}{dt} \\ + \dot{m}_{cw} C_{pw} (T_{cw, in} - T_{cw, out}) \end{aligned} \quad (6)$$

The mass balance for the refrigerant can be expressed as:

$$\frac{dW_{eva,w}}{dt} = -W_s \left(\frac{dq_{des-cond}}{dt} + \frac{dq_{eva-ads}}{dt} \right) \quad (7)$$

where, the subscripts *des-cond* and *eva-ads* stand for the vapor flow from desorber to condenser and evaporator to adsorber, respectively.

Measurement of the System Performance

The performance of a three-bed adsorption chiller with mass recovery is mainly characterized by cooling capacity (CC), and coefficient of performance (COP) and can be measured by the following equations:

Cooling Capacity (CC) =

$$\frac{\dot{m}_{chill} C_w \int_0^{t_{cycle}} (T_{chill, in} - T_{chill, out}) dt}{t_{cycle}}$$

Coefficient of Performance (COP) =

$$\frac{\dot{m}_{chill} C_w \int_0^{t_{cycle}} (T_{chill, in} - T_{chill, out}) dt}{\dot{m}_{hot} C_w \int_0^{t_{cycle}} (T_{hot, in} - T_{hot, out}) dt}$$

and the waste heat recovery efficiency (η) =

$$\frac{\dot{m}_{chill} C_w \int_0^{t_{cycle}} (T_{chill, in} - T_{chill, out}) dt}{\dot{m}_w C_w \int_0^{t_{cycle}} (T_{hot, in} - T_{cool, in}) dt}$$

Results and Discussion

In the present analysis, a cycle simulation computer program is developed to predict the performance of the three-bed (equal bed) chiller with mass recovery. The systems of differential equations (1)-(7) are

solved by finite difference approximation with a time step 1 sec. In the numerical solution of the differential equations, successive substitutions of the newly calculated values were used, with the iterative loop repeating the calculations until the convergence test is satisfied. The convergence factor for all parameters of the present study will be taken as 10^{-3} . The base line parameters and standard operating conditions for the chiller operation are listed in Table 2 and Table 3, respectively.

Table 2. Baseline Parameters

Symbol	Value	Unit
A _{hex}	1.45	m ²
A _{eva}	0.665	m ²
A _{con}	0.998	m ²
C _{ps}	924	J/kg.K
C _{pw}	4.18E+3	J/kg.K
C _{p,chill}	4.20E+3	J/kg.K
D _{so}	2.54E-4	m ² /s
E _a	2.33E+3	J/kg
L	2.50E+6	J/kg
Q _{st}	2.80E+6	J/kg
R	4.62E+2	J/kg.K
R _p	0.35E-3	m
U _{ads}	1380	W/m ² .K
U _{des}	1540	W/m ² .K
U _{eva}	3550	W/m ² .K
U _{cond}	4070	W/m ² .K
W _s	14	kg
W _{cw}	5	kg
C _{p,cu}	386	J/kg.K
C _{p,Al}	905	J/kg.K
W _{khex}	12.67	kg
W _{fhex}	5.33	kg
W _{eva,w}	25	kg

Table 3. Standard Operating Condition

	Temperature [°C]	Flow rate (kg/s)
Hot water	50 ~ 65	0.4
Cooling water	30	0.74 [=0.4(ads)+0.34(cond)]
Chilled water	14	0.11
Cycle Time	2400s=(1100 ads/ des+40 mr+30ph+30pc) s×2	

Effect of Driving Heat Source Temperature on CC and COP

Figure 2 and Figure 3 show heat source temperature variation on CC and COP, respectively. It is seen that CC for three-bed mass recovery chiller increases with

the increase of heat source temperature from 50°C to 65°C with a cooling water inlet temperature of 30°C. This is because the amount of refrigerant circulated increases, due to increased refrigerant desorption with higher driving source temperature. The CC is improved due to the mass recovery process. The mass recovery process generates more desorption heat and that is transferred from the desorber through desorbed vapor. So, in the low heat source temperature (50°C-65°C), proposed chiller gives better performance. The optimum COP value is 0.6214 for hot water inlet temperature at 65°C along with the coolant and chilled water inlet temperature are at 30°C and 14°C, respectively. The delivered chilled water temperature is 6°C for this operation condition.

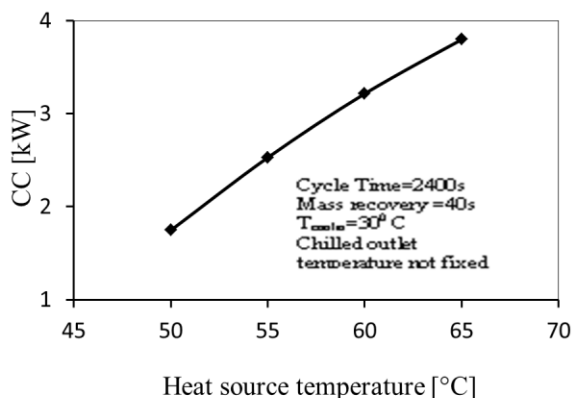

Figure 2. The effect of heat source temperature on CC

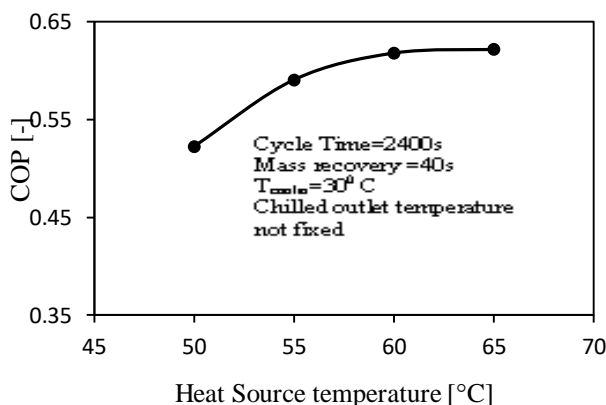

Figure 3. The effect of heat source temperature on COP

Effect of Cooling Source Temperature on CC and COP

Figure 4 and Figure 5 show the effect of cooling water inlet temperatures on CC and COP, respectively. In the present simulation, cooling water mass flow rate into adsorber is taken as 0.4 kg/s, while for the condenser the coolant mass flow rate is taken as 0.34 kg/s. The CC increases steadily as the cooling water inlet temperature is lowered from 40 to

20°C. This is due to the fact that lower adsorption temperatures result in larger amounts of refrigerant being adsorbed and desorbed during each cycle. The simulated COP values also increases with lower cooling water inlet temperature. For the three bed chiller the COP value reaches 0.6975 with 65°C driving source temperature in combination with a coolant inlet temperature of 20°C.

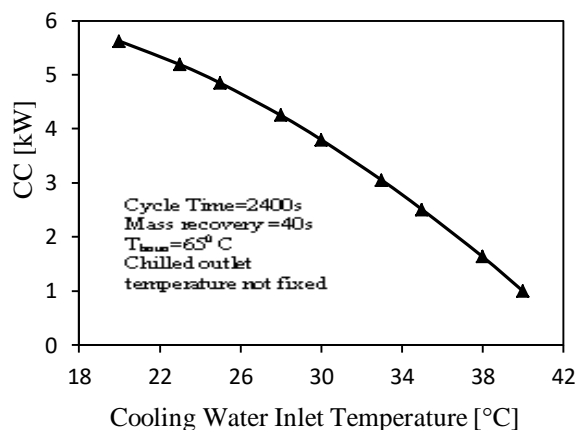

Figure 4. The effect of cooling water inlet temperature on CC

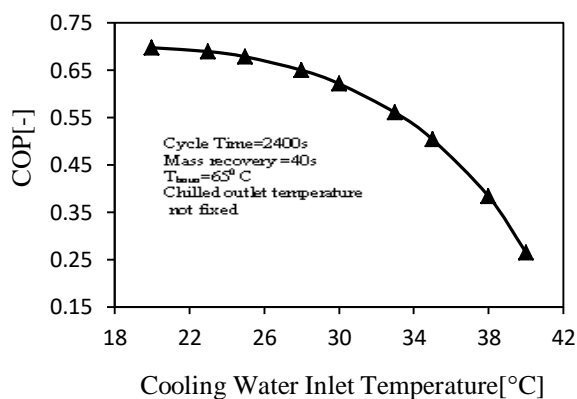

Figure 5. The effect of cooling water inlet temperature on COP

Effect of Cycle Time on CC and COP

CC and COP variations with adsorption/desorption cycle time are depicted in Figure 6. The sensible heating/cooling time is kept constant 30s. The highest CC values are obtained for cycle time between 2100s and 2700 s. When cycle times are shorter than 900s, there is not enough time for adsorption or desorption, so CC decreases abruptly. On the other hand, when cycle times are greater than 2700s, CC decreases gradually as the adsorbent approaches to its equilibrium condition. From the same Figure, it can also be observed that COP increases uniformly with longer cycle time.

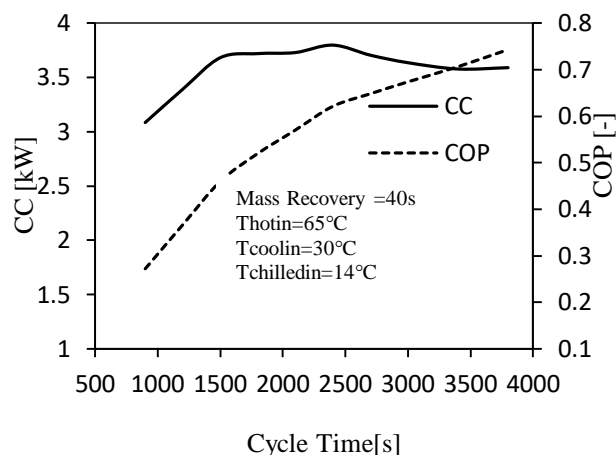

Figure 6. Cycle time effect on CC and COP

Conclusion

A three-bed mass recovery chiller with silica gel as adsorbent and water as adsorbate is proposed and the performances are evaluated by numerical technique. There is an increasing need for energy efficiency and requirement for the system driven with low temperature heat source. For the utilization of the demand, multi-bed mass recovery cycle is presented and the effects of operating conditions are investigated. The following concluding remarks can be drawn from the present analysis (for Figure 1- Figure 6):

- The main feature of the proposed chiller is the ability to be driven by relatively low temperature heat source. The chiller can utilize the fluctuated heat source temperature between 50°C to 65°C to produce effective cooling along with a coolant inlet at 30°C.
- In the cycle simulation study, hot and cooling water temperatures are the most influential parameters. CC increases with the increase of hot water temperature and opposite tendency for cooling

water temperature. Highest COP value (0.6214) is obtained for hot water inlet temperature at 65°C.

- In the low heat source temperature, COP improves significantly.
- Delivered outlet chilled water temperature of the proposed cycle decreases with the increase of driving heat source temperature.

References

1. Saha, B.B., Akisawa, A. and Kashiwagi, T. (2001). Solar/Waste heat driven two-stage adsorption chiller: The Prototype Renewable Energy, Vol.23, No.4. p.93-101.
2. Khan, M.Z.I., Saha, B.B., Alam, K.C.A., Akisawa, A. and Kashiwagi, T. (2005). Performance investigation on mass recovery three-bed adsorption cycle. International Conference on Mechanical Engineering, p.28-30.
3. Khan, M.Z.I., Sultana, S., Akisawa, A. and Kashiwagi, T. (2006). Numerical simulation of advanced adsorption refrigeration chiller with mass recovery. Journal of Naval Architecture and Marine Engineering, Vol.3, No.2. p.59-67.
4. Saha, B.B., Koyama, S., Kashiwagi, T. and Akisawa, A. (2003). Waste heat driven dual-mode, multi-stage, multi-bed regenerative adsorption system. International Journal of Refrigeration, Vol.26, p.749-757.
5. Saha, B.B., Koyama, S., Lee, J.B., Kuwahara, K., Alam, K.C.A., Hamamoto, Y., Akisawa, A. and Kashiwagi, T. (2003). Performance Evaluation of a low-temperature waste heat driven multi-bed adsorption chiller. International Journal of Multiphase Flow, Vol.29, p.1249-1263.
6. Shelton, S.V., Wepfer, J.W. and Miles, D.J. (1990). Ramp wave analysis of the solid/vapor heat pump. ASME Journal Energy Resources Technology, Vol.112, p.69-78.
7. Wang, R.Z. (2001). Performance improvement of adsorption cooling by heat and mass recovery operation. International Journal of Refrigeration, Vol.24, p.602-611.
8. Alam, K.C.A., Akahira, A., Hamamoto, Y., Akisawa, A. and Kashiwagi, T. (2004). A four-bed mass recovery adsorption refrigeration cycle driven by low temperature waste/renewable heat source. Renewable Energy, Vol.29, p.1461-1475.
9. Saha, B.B., Koyama, S., Ng, K.C., Hamamoto, Y., Akisawa, A. and Kashiwagi, T. (2006). Study on a dual-mode, multi-stage, multi-bed regenerative adsorption chiller. Renewable Energy, Vol.31, No.13. p.2076-2090.
10. Khan, M.Z.I., Saha, B.B. and Akisawa, A. (2011). Experimental study on a three-bed adsorption chiller. International Journal of Air-Conditioning and Refrigeration, Vol.19, No.4. p.285-290.